

# Heating/Cooling and Snow Melting Systems Using Geothermal Heat Pumps

## 【 Heating/cooling and sidewalk snow melting system at the Machinaka Information Center in Hirosaki 】

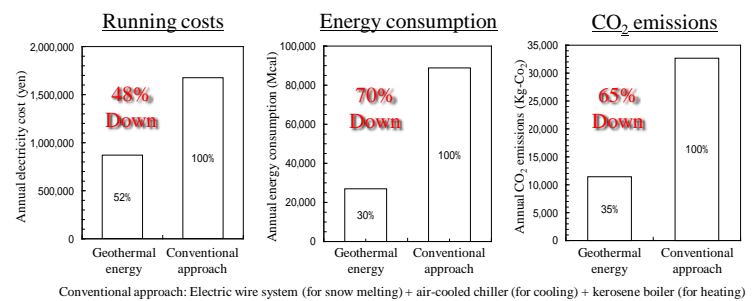

Application in greenhouse farming (Kizukuri-machi, Aomori Prefecture)

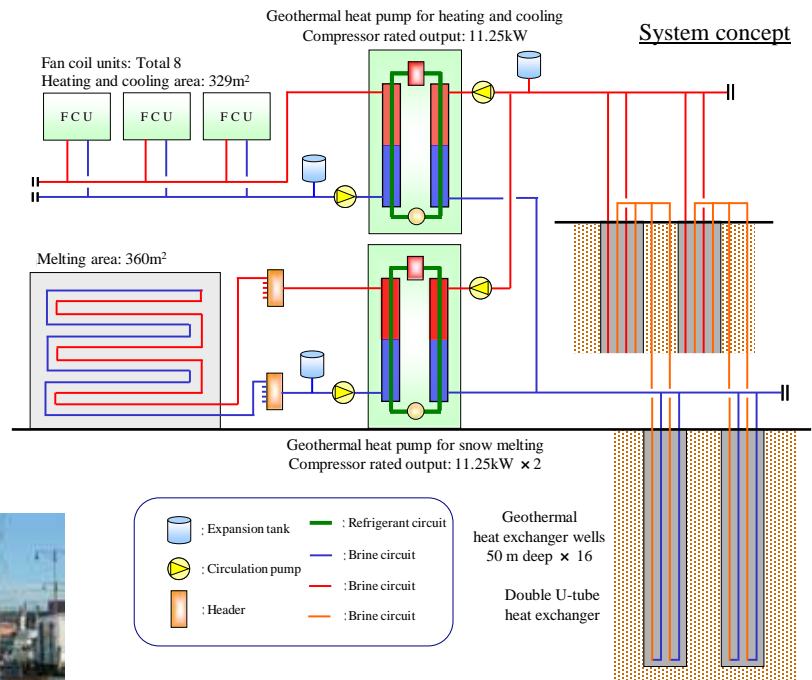

Road snow melting (Kitaakita City, Akita Prefecture)



Heating and cooling (Misato-cho, Akita Prefecture)



◆ Inquiries to:

Drilling Department, Natural Resources and Energy Engineering Division  
 1-14-16, Kudan Kita, Chiyoda-ku, Tokyo 102-8205  
 1-3-6, Ogimachi, Oaza, Hirosaki-shi, Aomori Prefecture 036-8104

TEL +81-3-3221-2471 FAX +81-3-3221-2472  
 TEL +81-172-29-5171 FAX +81-172-29-5173

